

**General Grading Notes**

- THIS CONSTRUCTION SHALL BE IN ACCORDANCE WITH THE FOLLOWING SPECIFICATIONS:
  - "STANDARD SPECIFICATIONS FOR ROAD AND BRIDGE CONSTRUCTION", ADOPTED JANUARY 1, 2007, BY THE ILLINOIS DEPARTMENT OF TRANSPORTATION.
  - "SUPPLEMENTAL SPECIFICATIONS AND RECURRING SPECIAL PROVISIONS", CURRENT YEAR EDITION, BY THE ILLINOIS DEPARTMENT OF TRANSPORTATION.
  - "STORM WATER MANAGEMENT FOR CONSTRUCTION ACTIVITIES", ADOPTED SEPTEMBER, 1992 BY THE UNITED STATES ENVIRONMENTAL PROTECTION AGENCY.
- THE EROSION CONTROLS SHOWN ON THIS PLAN ARE THE MINIMUM REQUIRED. CONTRACTOR IS RESPONSIBLE FOR PROVIDING ADDITIONAL EROSION CONTROLS AS THE PROJECT PROGRESSES AS INDICATED ON THE CORRESPONDING PLAN SHEETS AND AS NECESSARY TO COMPLY WITH CITY AND IEPA PERMITS. ALL ADDITIONAL EROSION CONTROLS THAT MAY BE REQUIRED BUT ARE NOT SHOWN ON THE PLANS SHALL BE INCIDENTAL TO THE CONTRACT.
- THE CONTRACTOR SHALL CONTINUE TO MAINTAIN ALL EROSION CONTROL FACILITIES UNTIL FINAL ACCEPTANCE BY THE OWNER AND CITY OF PEORIA.
- CONTRACTOR IS RESPONSIBLE FOR REMOVAL OF ALL TOPSOIL, TREES, STUMPS, ROOTS AND ORGANIC MATERIAL IN AREAS OF BUILDINGS, PAVEMENT AND SIDEWALKS. WHERE UNSUITABLE SUBSOILS EXIST AFTER REMOVAL OF TOPSOIL, CONTRACTOR SHALL NOTIFY OWNER PRIOR TO PLACING ANY FILL MATERIAL. SUITABLE TOPSOIL SHALL BE STOCKPILED ON SITE FOR USE ON THIS PROJECT.
- UNLESS OTHERWISE INDICATED, ALL PROPOSED SPOT ELEVATIONS ARE TO TOP OF CONCRETE OR PAVEMENT.
- ALL GROUND ELEVATIONS ADJACENT TO PROPOSED BUILDINGS SHALL BE BELOW THE FINISHED FLOOR ELEVATION OF THE BUILDING. LOTS SHALL BE GRADED TO DRAIN AWAY FROM PROPOSED BUILDINGS AT A MINIMUM SLOPE OF 1.0%.
- ALL LOTS SHALL BE GRADED TO MAINTAIN A SWALE ON THE SIDE LOT LINES BETWEEN ADJACENT DRIVEWAYS PER THE MASS GRADING PLAN.
- ALL PROPOSED GROUND ELEVATIONS ARE TO FINISHED SURFACE. SEE LANDSCAPING PLANS FOR TOPSOIL REQUIREMENTS AND FINISHED GROUND SURFACES.

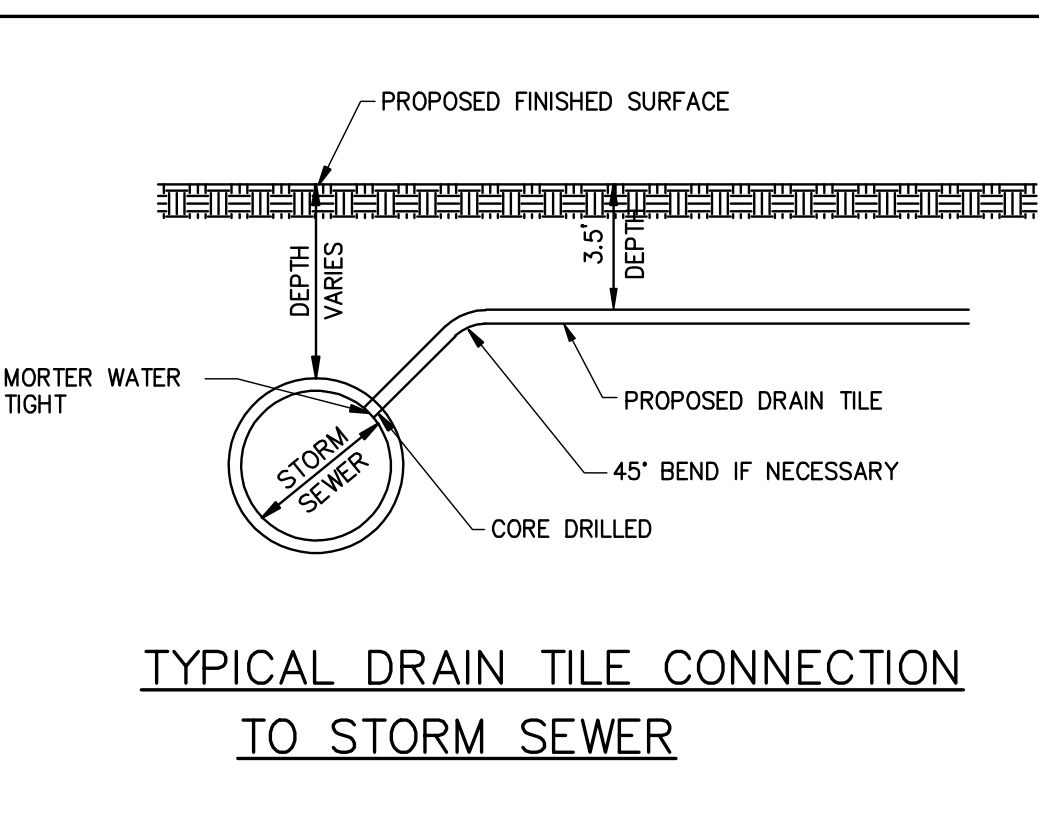
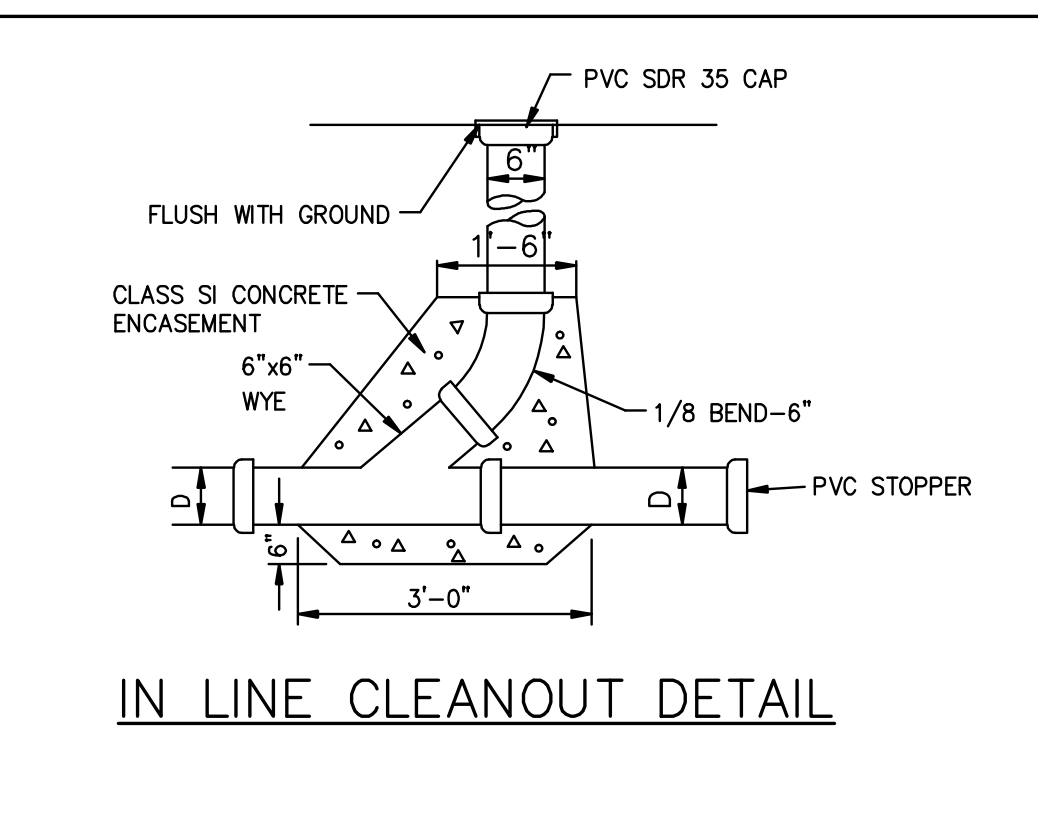
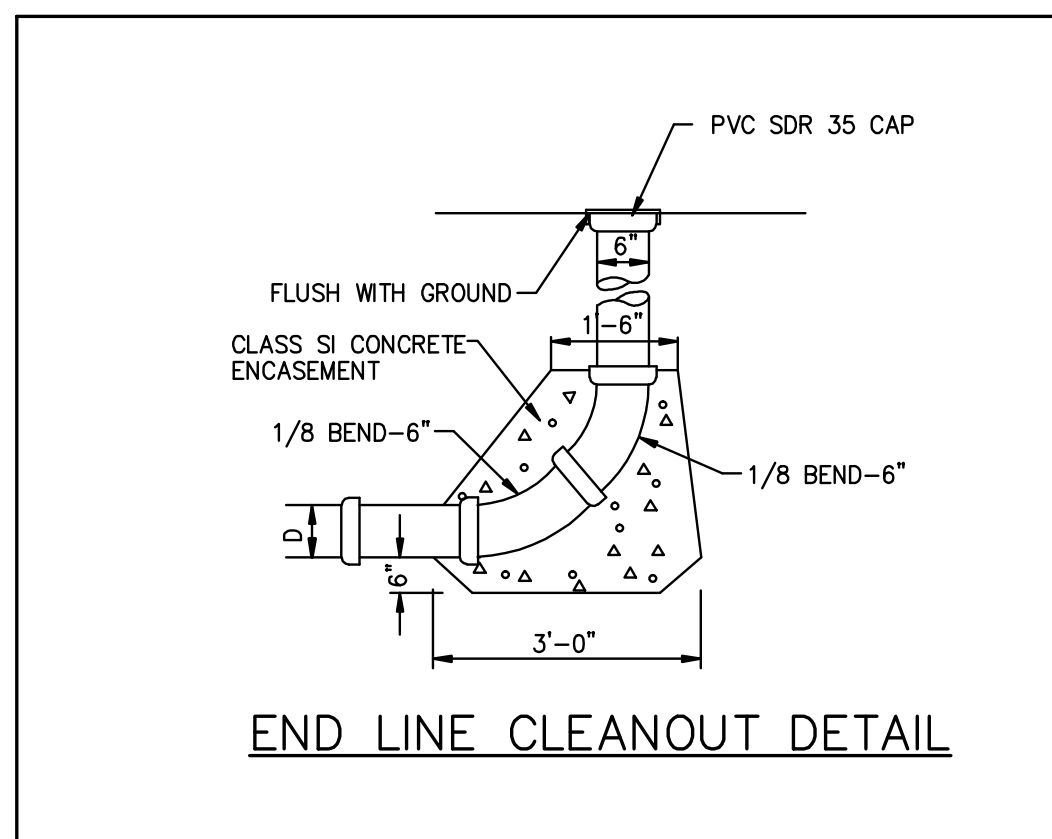

XRef Files: \\0080282.00-xr-pla-phase-ii |  
 | ereshman | P: peoria housing authority 2009 | 0090282.00-pla - harrison phase 2 office & seniors | dwg | sheets | pha | site | stn | dwg | DATE: 07/10/2009 | TIME: 07:57 |